

Netalkars'...

- enduring precision

since 50 years...

Operating through a modern
Facility @

**M/s. SRINIVAS INDUCTION
HARDENING**



Organisation – An Evolution

- 1965** – Inception of First Plant with ‘Solitary’ Man-Machine-Manager combination
- 1985** – Supplier to O.E.M – Fully Finished
- 1991** – 2nd Unit with ‘Semi-Finish’ Capability.
- 1997** – S.I.H was established primarily for having Induction Hardening Facility
- 2004** – 4th Plant NPT 2 was established..
- Today:** 1 Lakh Sq. Ft. of Workshop area & Employee base of 600+; Strong Customer Base + ‘Strategic Operation’

Legacy that we bank upon...

- ✓ **Goldsmith's precision...**
- ✓ **Experiential Expertise...**
- ✓ **Learners' Approach...**



Milestones we're aspiring @



Our Mission...

“To facilitate speedier, efficient, safe movement of people, material and matter through transmission of energy”



We are relentlessly after..

PPM < 500

OEE > 75%

Annual Sales
Turnover X²



Labour
Productivity X²

Building
Competencies...

Satisfying all the
stakeholders...

We Strive to adhere to..

A yellow thought bubble with a gold outline and a dotted pattern, containing the text 'Transparent Communication'.

**Transparent
Communication**

A yellow thought bubble with a gold outline and a dotted pattern, containing the text 'Collaboration for Innovation'.

**Collaboration
for
Innovation**

A yellow thought bubble with a gold outline and a dotted pattern, containing the text 'Commitment driven by Discipline'.

**Commitment
driven by
Discipline**

A yellow thought bubble with a gold outline and a dotted pattern, containing the text 'Respect for Individuals'.

**Respect for
Individuals**

We have been offering...

**Francois Compressor
Lister Petter
Durante M&M
Yuvraj M&M**

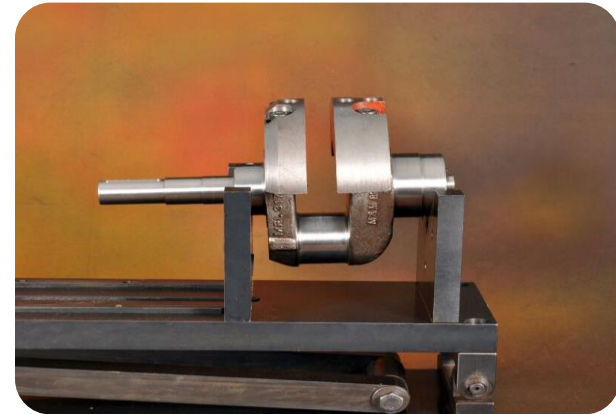

**Arctic Circle
L2E MHI
Yuvraj Next M&M
Eagle M&M**



We have been offering...

Three Cylinder

Eagle
M&M



John Deere

LS/Up-
speeded



Defiance

L3/S3
Mitsubishi



Renault
Nissan

NEF Series
{M&M}



Kirloskar

We have been offering... **Four Cylinder**

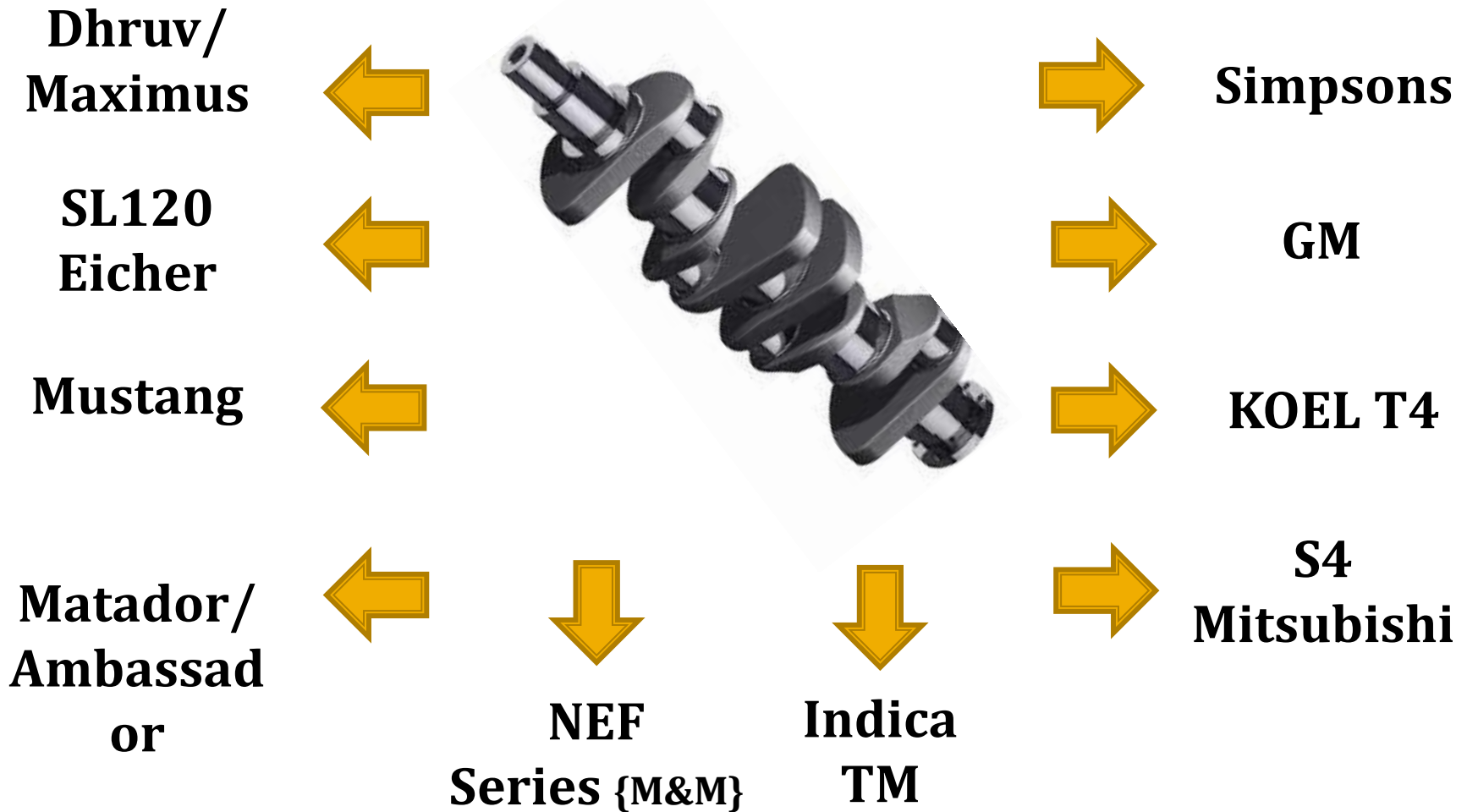

Our Technological Prowess...

100 % In-house capability for Crankshaft Machining process



**Pre-Machining
on CNC
Heller, BFW,
Miven,
Warners Swasi**

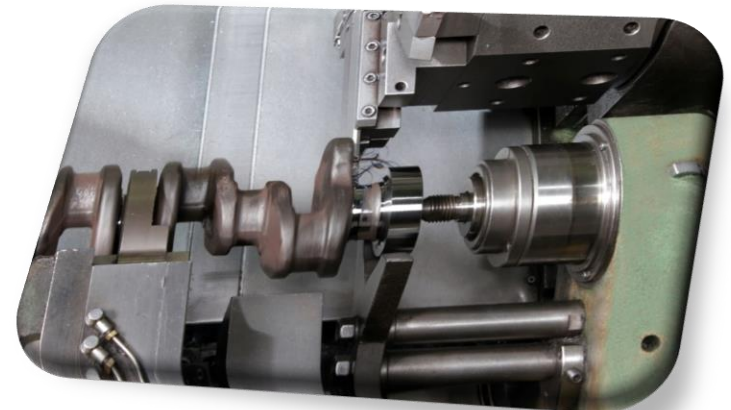

Our Technological Prowess...

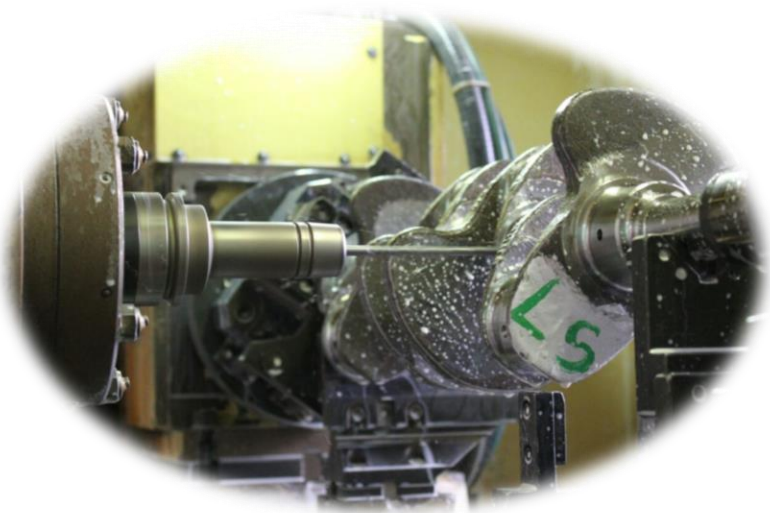

Custom-
designed
IH Mach.



BFW Oil Hole,
CNC Induction
Hardening

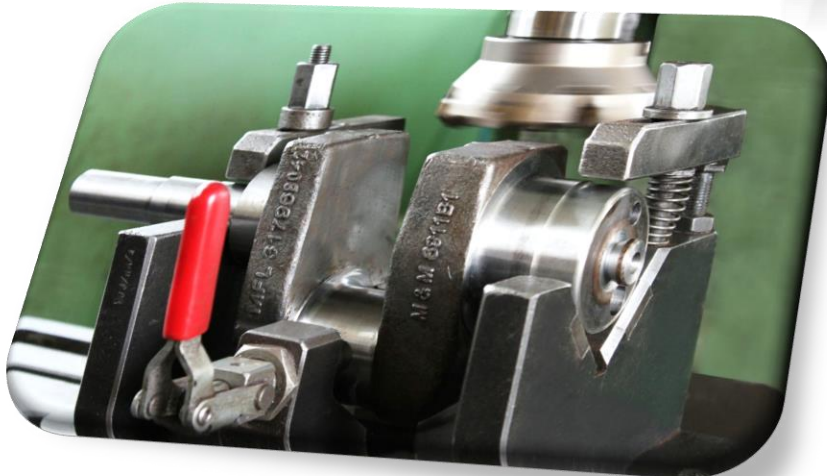

Our Technological Prowess...



Automatic
Balancing
Machine from
Grind Master

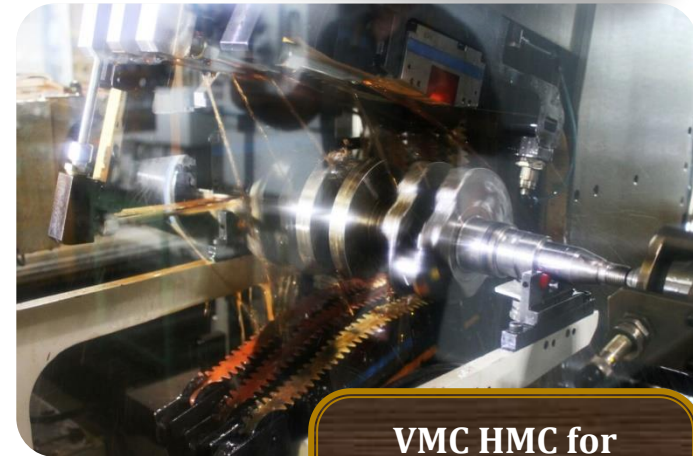

VMC HMC for
Flange Hole
drilling, Tapping
and Reaming

Ensuring Precision Per se...

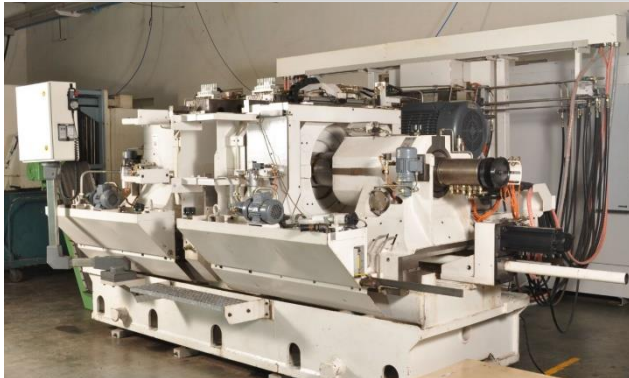

**Orbital Grinding
Machines from
NTC and Landis &
Heller machines**



Authenticating our precision..

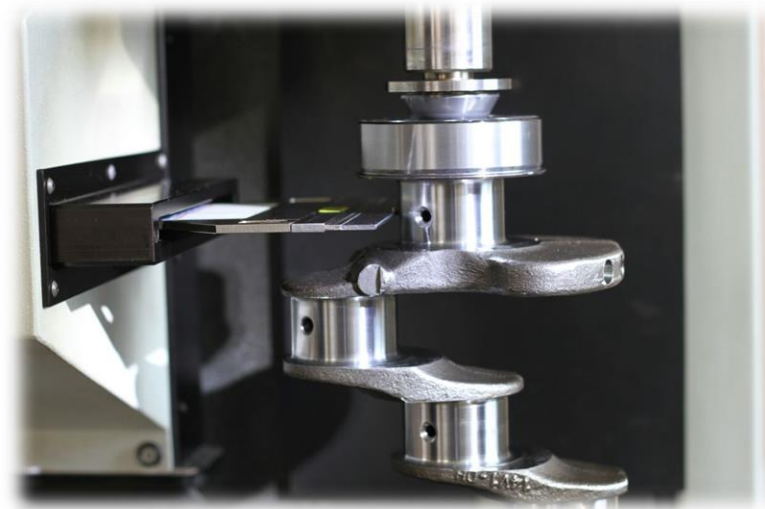

Adcole, Contracer, CMM, Micro Hardness Tester, Radius surface finish tester



Authenticating our precision..

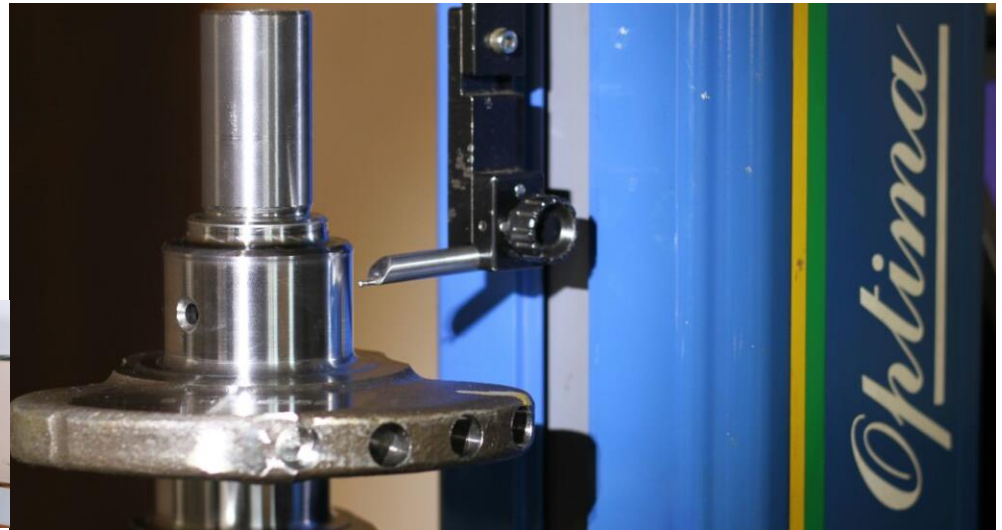
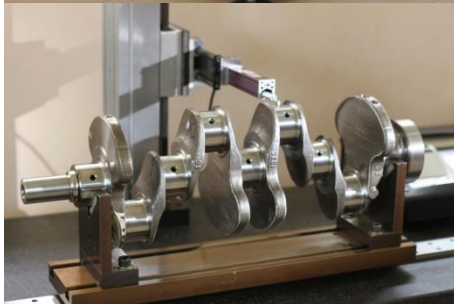
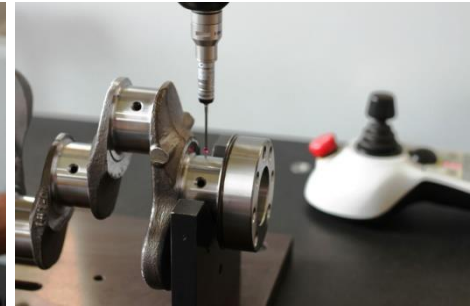

Straight out of Cerebros...

+ We have in our arsenal few custom-designed machines....



Finish Bore..



Smallest Induction Hardening Mach. Within 120 Sq. Ft.

Smallest Key Way Milling.. 16 Sq. ft.



Execution Per Se...

The % has been on the rise with increase in Load/Demand...

OVERALL EQUIPMENT EFFICIENCY %

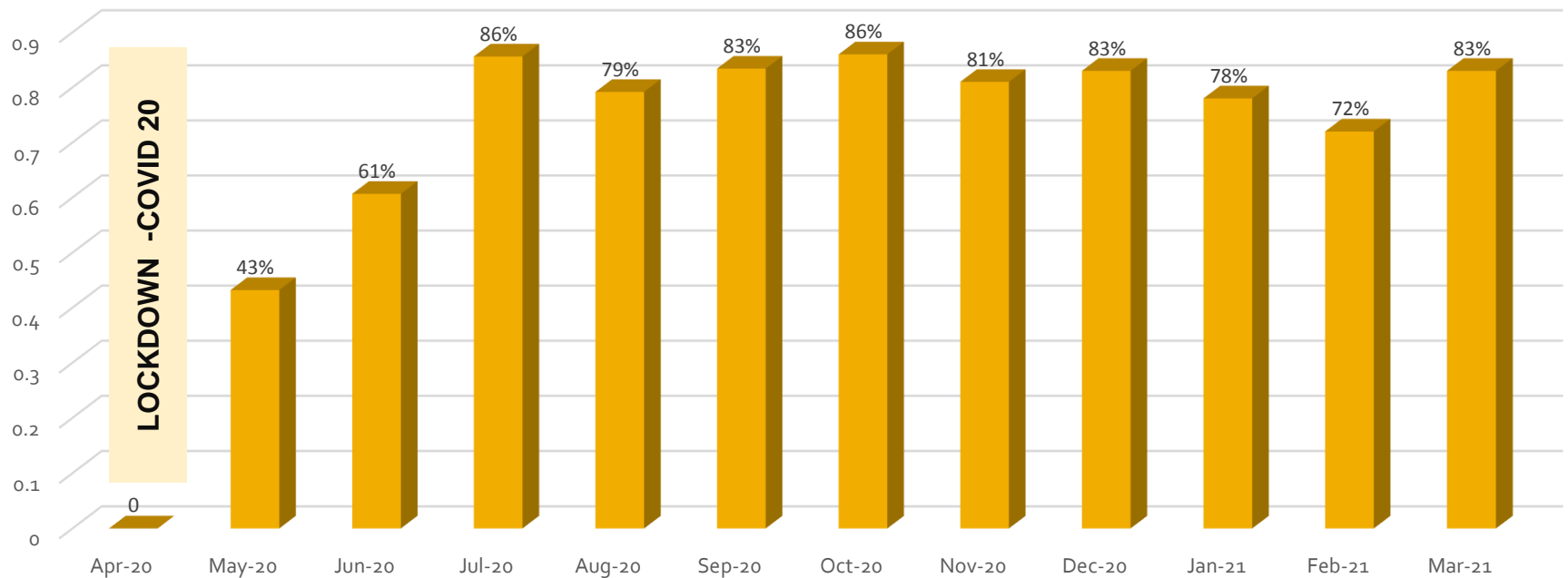

Execution Per Se...

These numbers points us out that we have a spare capacity...

Machine Utilization

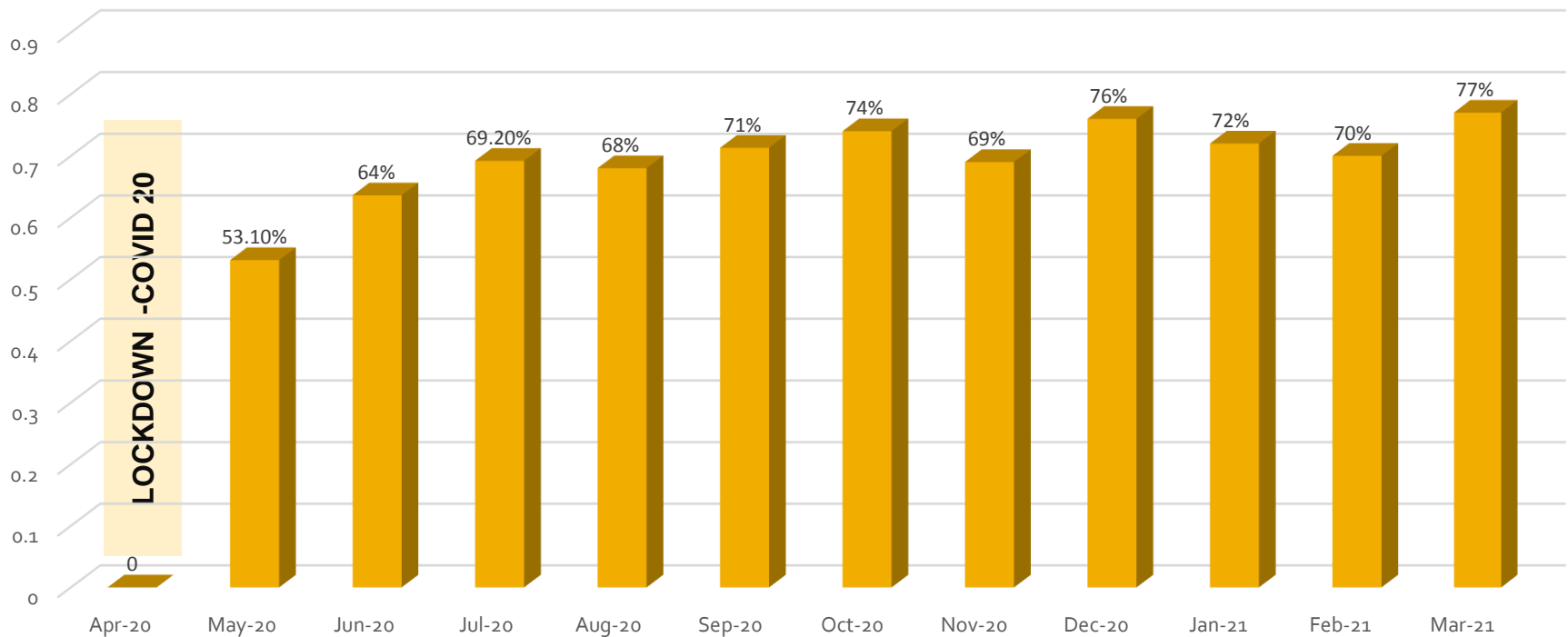

Execution Per Se...

TESTIMONIALS - QUALITY							
Month	Total Production	At OUR End...			At Customer End...		
		QTY	%	PPM	QTY	%	PPM
Mar-20	10370	57	0.55%	5497	1	0.01%	96
Apr-20	0	0	0.00%	0	0	0.00%	0
May-20	7301	43	0.59%	5890	0	0.00%	0
Jun-20	17467	83	0.48%	4752	1	0.01%	57
Jul-20	18570	133	0.72%	7162	1	0.01%	54
Aug-20	18071	71	0.39%	3929	2	0.01%	111
Sep-20	19258	133	0.69%	6906	0	0.00%	0
Oct-20	19803	166	0.84%	8383	1	0.01%	50
Nov-20	17688	161	0.91%	9102	0	0.00%	0
Dec-20	20629	107	0.52%	5187	1	0.00%	48
Jan-21	19005	160	0.84%	8419	0	0.00%	0
Feb-21	17230	180	1.04%	10447	0	0.00%	0

We are Striving to improve on this through monthly PARETO...

Execution Per Se...

Customer Complaints vis-à-vis Dispatch

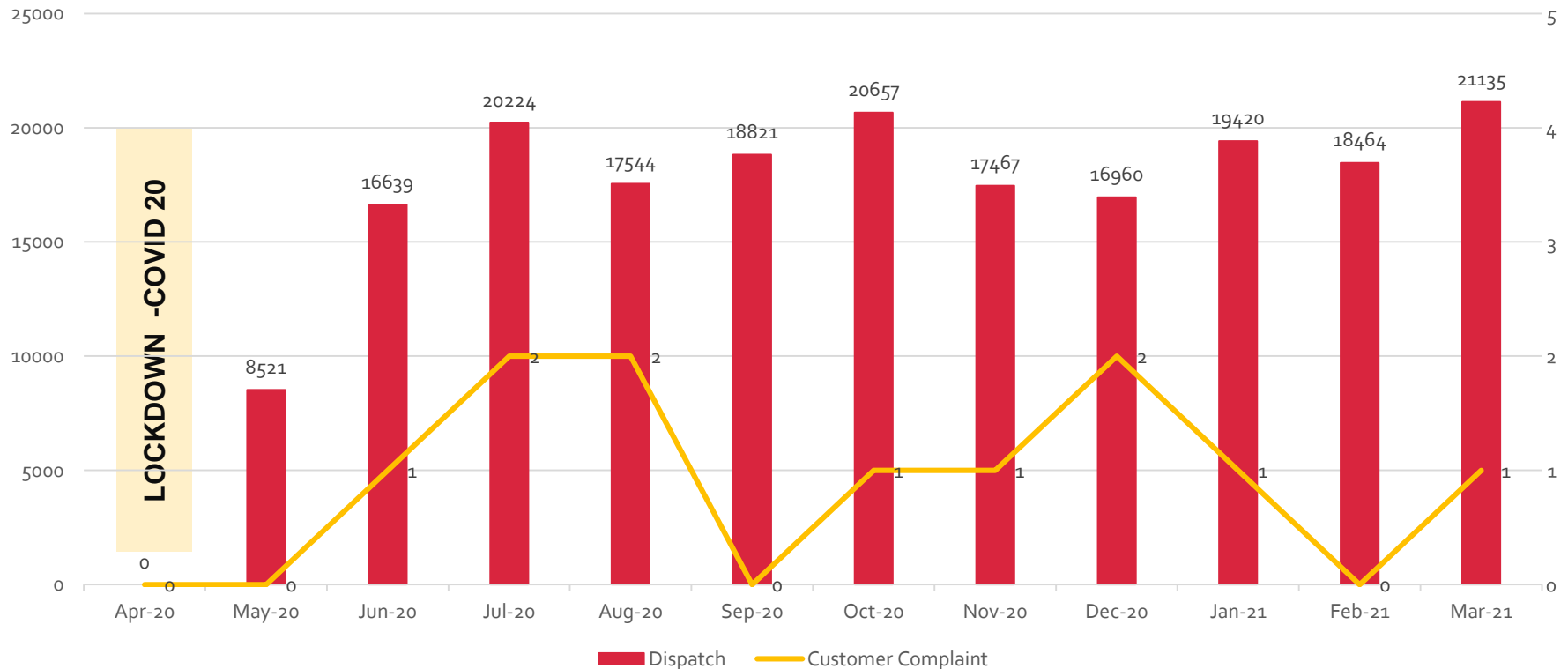

Execution Per Se...

Performance Scorecard from Customers...

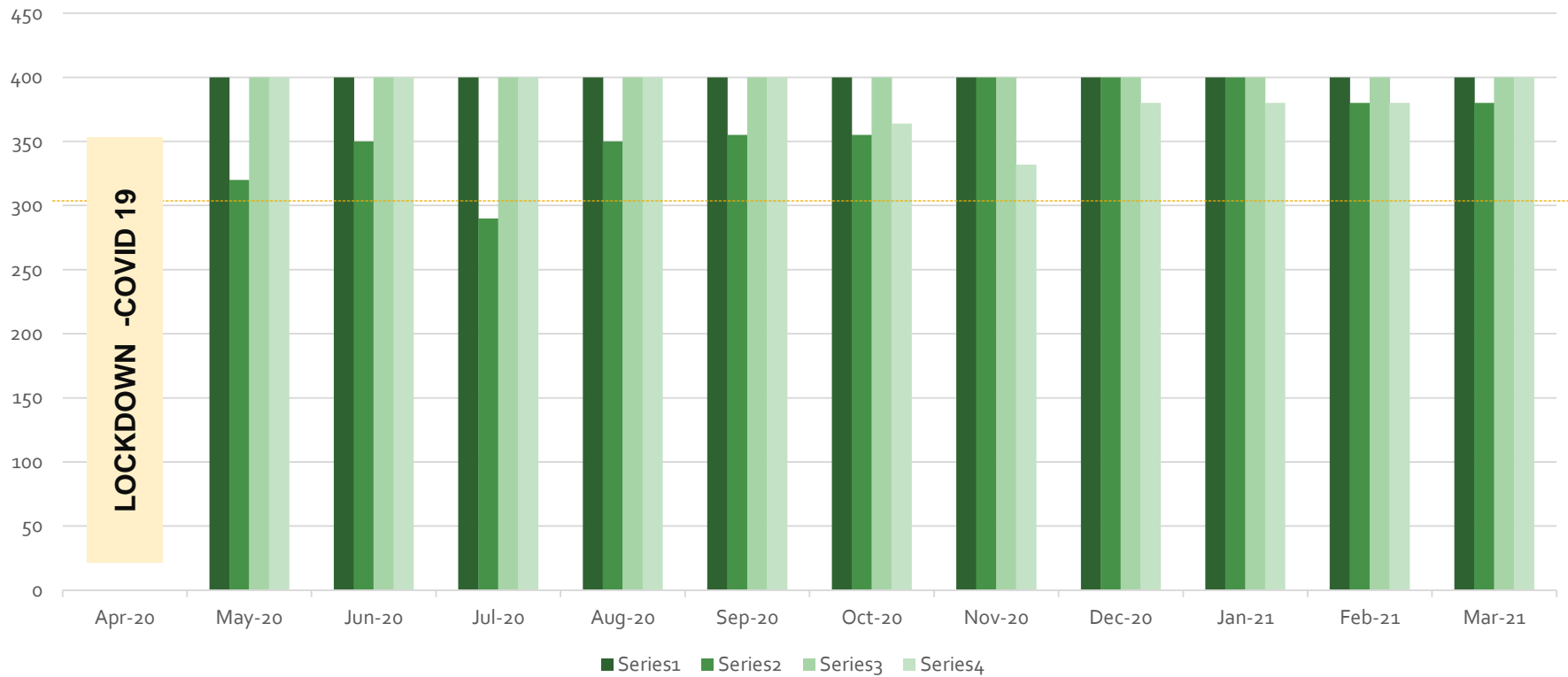

- Mahindra & Mahindra FES
- Mahindra & Mahindra AD
- MVDE
- KOEL

Target : 300

Execution Per Se...

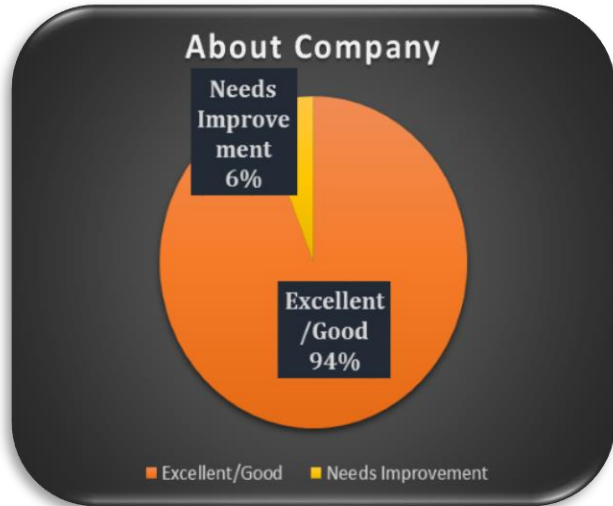

“Employee Satisfaction” (anonymously) is assessed half yearly and acted upon...

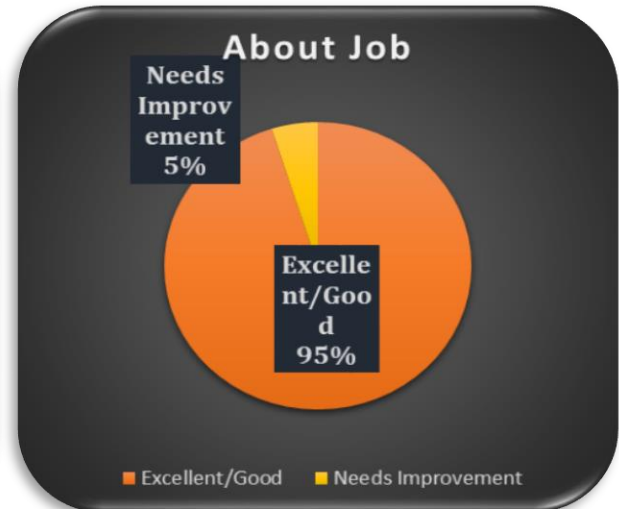

Competitive Advantage..



**Cost Competitiveness -
Through Efficiency**



**Less than
30 Mins...**



**Set-Up & Change over
time required...**

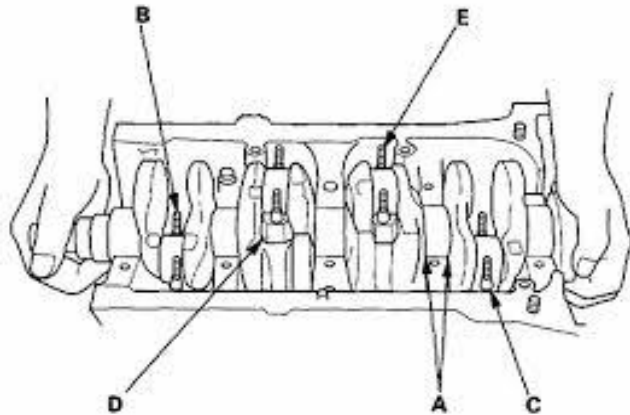

**Development of Crankshaft in
less than 50 Days...**

First Time First Piece Right Attitude...

This provides an extra EGDE..

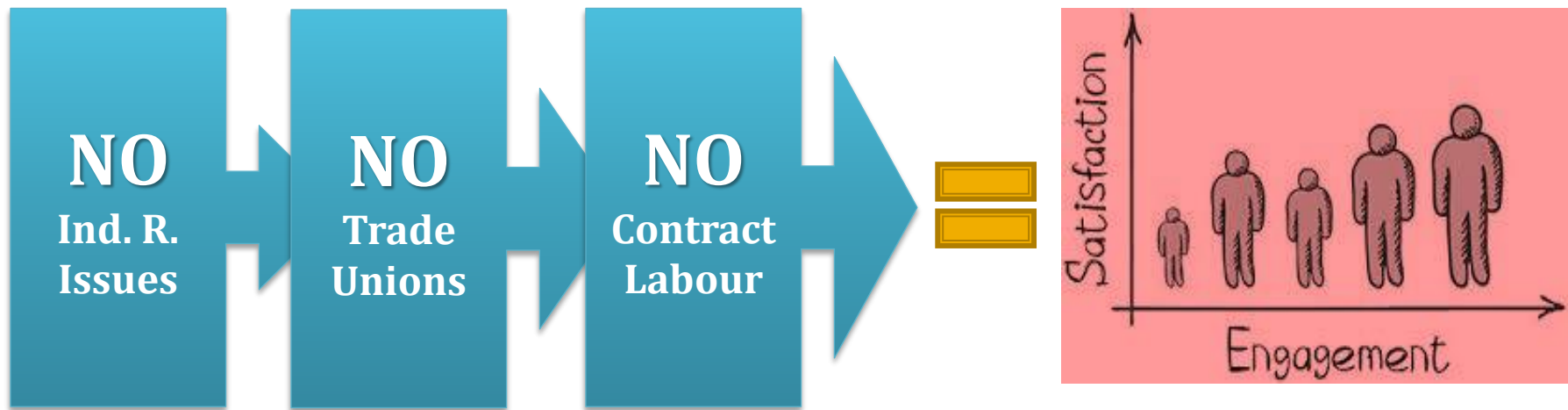

- ↪ ***Vector Grinding Machines – New Technology – 02 Nos.***
- ↪ ***Capacity improved from 740 to 1000 Numbers***
- ↪ ***“Plan B” for all the critical operations/machines..***
- ↪ ***Indigenous Knowledge base of Imported Machines***

What we offer as "USP"..??

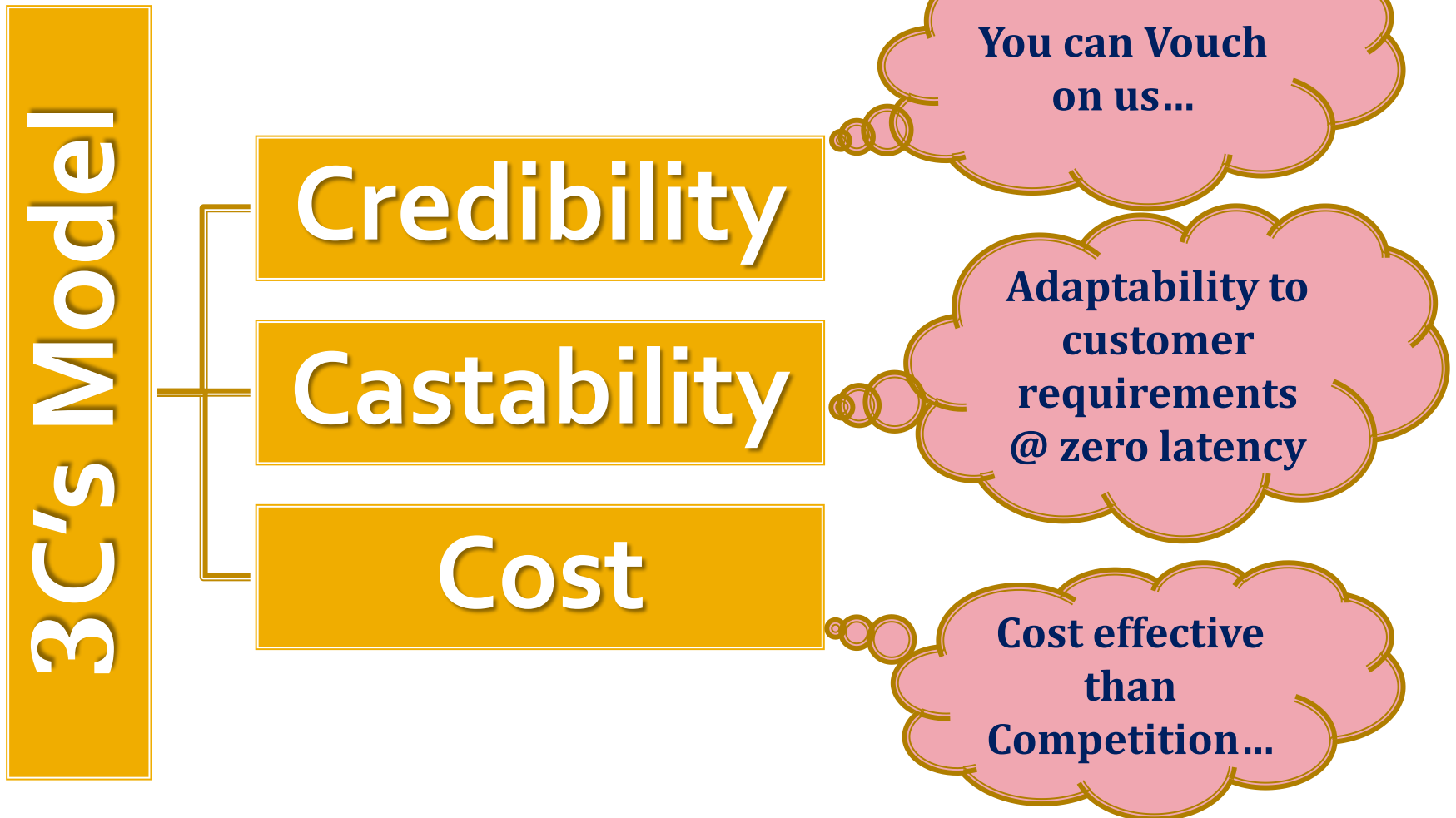

Recognitions & Awards...



Best Supply Chain Member Award: M&M FES 2007

Best Product Development Award M&M 2007

Outstanding Performance M&M FES 2008

New Product Development Award MVDE 2014

Self Certified Quality Supplier Award MVDE 2018

Supplier of The Year Award MVDE 2019

Self Certified Quality Supplier Award MVDE 2019

Defect Free Supply Award – KOEL 2019

Best Quality Performance M&M 2019

Supplier Excellence Award M&M 2019

Supplier Excellence SCM Award M&M 2021

Certifications...



IATF 16949



Both of our plants have been certified in the year 2017-18

Srinivas Induction Hardening is Safety, Health and Environment Certified

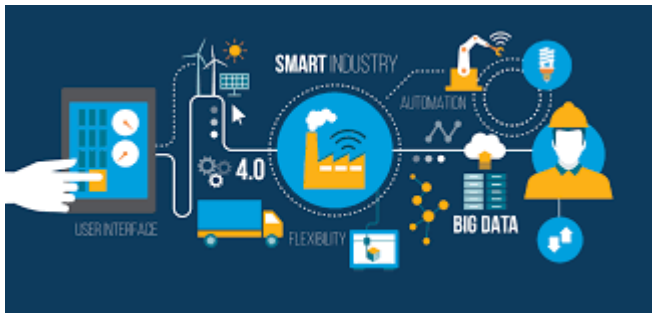

Visual Percept & Conceptualisation of Industry 4.0 – Ready to go

Clientele...



Enriching Lives



Contact us @...

NETALKAR

www.sihnetalkar.com

M/s. Srinivas Induction Hardening

414/1 & 414/2, Khanapur Road,
P.O. Macche, Belgaum - 590014

Karnataka. INDIA

Ph. No. +91-831-2411640

dayanand@netalkar.co.in

srinivas@netalkar.co.in

+919341102605



Thank
You

